

ultrasonic sensor
diffuse mode sensor
RU30-Q30-AP8X-H1141

TURCK

Industrial
Automation

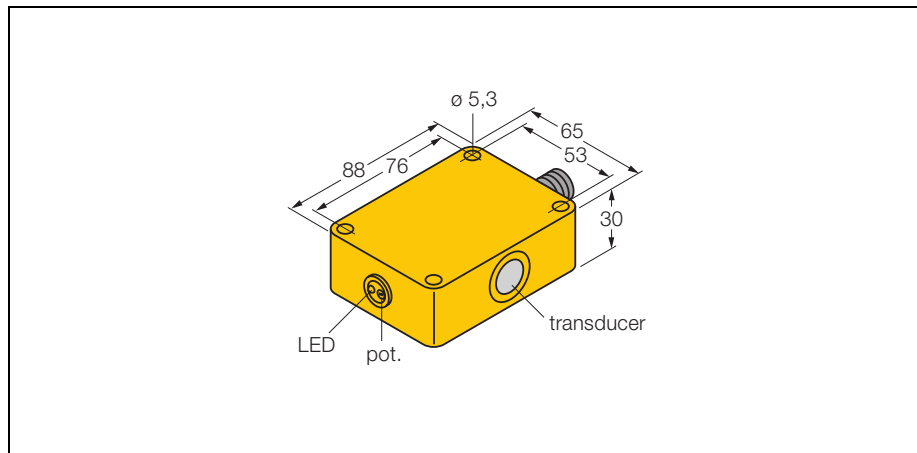

- ultrasonic sensor
- upper switching range value adjustable via potentiometer
- plastic housing
- synchronizable
- opening angle of sonic cone 6°

Wiring diagram

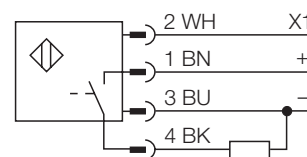

Functional principle

Ultrasonic sensors use ultrasonic waves for non-contact and wear-free detection of a large variety of objects. It does not matter whether the object is transparent or opaque, metallic or non-metallic, or of liquid, solid or powdery consistence. Environmental conditions such as spray, dust or rain hardly affect their function.

Type	RU30-Q30-AP8X-H1141
Ident-No.	1820000
Range	6... 30 cm
Ultrasound frequency	400 kHz
Temperature drift	0.17 % / K
Repeatability	≥ ± 0.45 mm
Edge lengths of the nominal actuator	10 mm
Pass speed	1.5 m/s
Approach speed	4 m/s
Ambient temperature	0...+ 55 °C
Operating voltage	18... 35VDC
DC rated operational current	100 mA
No-load current I_0	35 mA
Output function	normally open, pnp
Short-circuit protection	yes / cyclic
Reverse polarity protection	complete
Switching frequency	8 Hz
Voltage drop at I_e	2V
Wire breakage protection	yes
Housing	rectangular, Q30
Dimensions	88 x 65 x 30 mm
Housing material	plastic, PBT-GF30-V0
Connection	connectors, M12 x 1
Degree of protection	IP65
Display switch state	LED yellow