

**Inductive sensor
with extended switching distance
Bi2-EH6,5-AN6X-V1131**

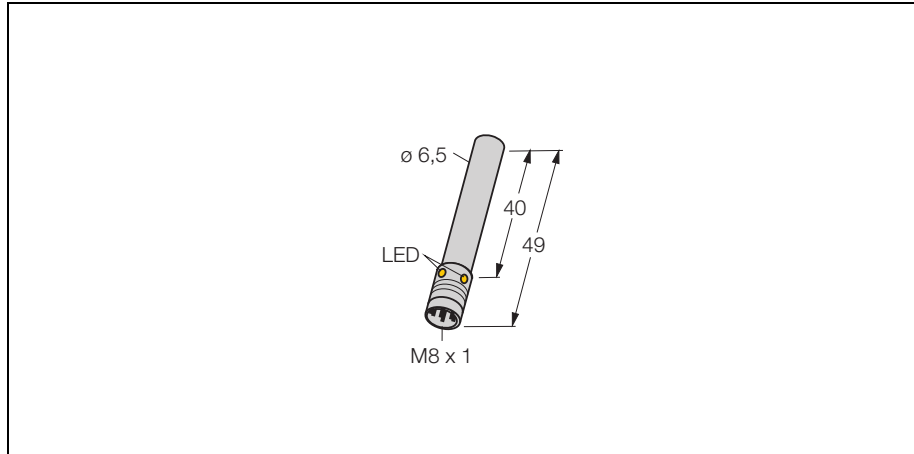

- smooth barrel, 6.5 mm diameter
- stainless steel, 1.4404
- large detection range
- 3-wire DC, 10...30 VDC
- normally open npn output
- connector, M8 x 1

Wiring diagram

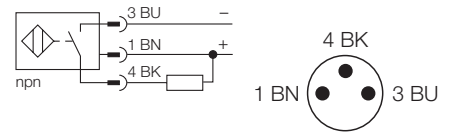

Type	Bi2-EH6,5-AN6X-V1131
Ident-No.	4612320
Rated operating distance Sn	2 mm
Mounting condition	flush
Assured sensing range	(0,81 x Sn) mm
Correction factors	St37 = 1, V2A ~ 0.7, Ms ~ 0.4, Al ~ 0.3
Repeatability	2 %
Temperature drift	± 10 %
Hysteresis	3... 15 %
Ambient temperature	-25...+ 70 °C
Operating voltage	10... 30VDC
Residual ripple	10 % U _{SS}
DC rated operational current	150 mA
No-load current I ₀	15 mA
Residual current	0.1 mA
Rated insulation voltage	0.5 kV
Short-circuit protection	yes / cyclic
Voltage drop at I _e	1.8V
Wire breakage / Reverse polarity protection	yes / complete
Output function	3-wire, normally open, npn
Switching frequency	3 kHz
Housing	smooth barrel, 6.5 mm
Dimensions	49 mm
Housing material	metal, AISI 316L
Material active face	plastic, plastic, PA12-GF20
Connection	connectors, M8 x 1
Vibration resistance	55 Hz (1 mm)
Shock resistance	30g (11 ms)
Degree of protection	IP67
Display switch state	LED yellow

Functional principle

Inductive sensors are designed for wear-free and non-contact detection of metal objects. For this purpose they use a high-frequency electro-magnetic AC field that interacts with the target. With inductive sensors, this field is generated by an LC resonant circuit with a ferrite core coil.

**Inductive sensor
with extended switching distance
Bi2-EH6,5-AN6X-V1131**

Mounting instructions	minimum distances
Distance D	2 x B
Distance W	3 x Sn
Distance T	3 x B
Distance S	1,5 x B
Distance G	6 x Sn

Diameter of the active area B	Ø 6.5 mm
--------------------------------------	----------

